

WORLD'S MOST
EFFICIENT BACKHOE



MODELS

HEAVY DUTY
HD 76

CHAMPION
SD 76

SUPER SMART
SD 76

CHALLENGER
CH 76





HEAVY DUTY - HD 76

CHAMPION - SD 76

SUPER SMART - SD 76

CHALLENGER - CH 76

| | | | | |
|---------------------|--|---|---|--|
| ENGINE | Kirloskar 4R1190NA, BS-IV (CEV) Diesel Engine (4760cc) Gross Power : 74.5HP (54.8kW) @ 2200 rpm Gross Torque : 300Nm @ 1300 rpm | Kirloskar 4R1190NA, BS-IV (CEV) Diesel Engine (4760 CC) Gross Power : 74.5HP (54.8kW) @ 2200 rpm Gross Torque : 300Nm @ 1300 rpm | Kirloskar 4R1190NA, BS-IV (CEV) Diesel Engine (4760 CC) Gross Power : 74.5HP (54.8kW) @ 2200 rpm Gross Torque : 300Nm @ 1300 rpm | Kirloskar 4R1040NA, BS-III (CEV) Diesel Engine (4160 CC) Gross Power : 49HP (36kW) @ 2000 rpm Gross Torque : 250Nm @ 1200 rpm |
| TRANSMISSION | CARRARO Synchro-shuttle Transmission with integral torque convertor (Ratio : 2.64) | CARRARO Synchro-shuttle Transmission with integral torque convertor (Ratio : 2.64) | CARRARO Synchro-shuttle Transmission with integral torque convertor (Ratio : 2.64) | CARRARO Synchro-shuttle Transmission with integral torque convertor (Ratio : 2.64) |
| STEERING | Power Steering | Power Steering | Power Steering | Power Steering |
| ELECTRICALS | 12V Battery System (150Ah) | 12V Battery System (150Ah) | 12V Battery System (150Ah) | 12V Battery System (150Ah) |
| TYRES | FRONT 2WD 9.00X16 - 16PR 4WD 12.5/80X18 - 12PR REAR Industrial : 16.9X28 - 12PR Heavy Duty : 14X25 - 20PR | FRONT 2WD- 9.00X16 - 16PR 4WD- 12.5/80X18 - 12PR REAR Industrial : 16.9X28 - 12PR Heavy Duty : 14X25 - 20PR | FRONT 2WD- 9.00X16 - 16PR 4WD- 12.5/80X18 - 12PR REAR Industrial : 16.9X28 - 12PR Heavy Duty : 14X25 - 20PR | FRONT 2WD- 9.00X16 - 16PR REAR Industrial : 16.9X28 - 12PR Heavy Duty : 14X25 - 20PR |
| SPEED | Forward Max 39 Km/Hr Reverse Max 9.3 Km/Hr (2nd Gear) | Forward Max : 39 Km/Hr Reverse Max : 9.3 Km/Hr (2nd Gear) | Forward Max : 39 Km/Hr Reverse Max : 9.3 Km/Hr (2nd Gear) | Forward Max : 36 Km/Hr Reverse Max : 8.3 Km/Hr (2nd Gear) |
| HYDRAULICS | Pump Type : Gear Pump Pressure : 3335 p.s.i (230 bar) Pump Flow : 113 lpm @ 2200 rpm 122 lpm @ high rpm | Pump type : Gear Pump Pressure : 3335 p.s.i (230 bar) Pump Flow : 113 lpm @ 2200 rpm 122 lpm @ high rpm | Pump type : Load Sensing Variable Piston Pump Pressure : 3335 p.s.i (230 bar) Pump Flow : 119 lpm @ 2200 rpm 128 lpm @ high rpm | Pump type : Load Sensing Variable Piston Pump Pressure : 3335 p.s.i (230 bar) Pump Flow : 119 lpm @ 2200 rpm 128 lpm @ high rpm |
| WEIGHT | 8160 Kgs Available Variant : EX+ / LX+ / JX+ / AX+ | 8010 Kgs Available Variant : EX+ / LX+ | 8010 Kgs Available Variant : EX+ / LX+ / JX+ | 7550 Kgs Available Variant : EX+ |

| FEATURES | VARIANT | EX+ | LX+ | JX+ | AX+ |
|--|---------|-----|-----|-----|-----|
| Air Condition/with Heater (Option) | | X | ✓ | O | ✓ |
| Agile Joystick Drive With Ajs Technology | | X | X | ✓ | ✓ |
| Suspension Seat | | X | ✓ | ✓ | ✓ |
| Adjustable Steering Provision | | ✓ | ✓ | ✓ | ✓ |
| Radio/music System | | ✓ | ✓ | ✓ | ✓ |
| Co-driver Seat | | ✓ | ✓ | ✓ | ✓ |
| Bonnet Opening From Inside Cabin | | ✓ | ✓ | ✓ | ✓ |
| Eco/speed Mode Automatic | | ✓ | ✓ | ✓ | ✓ |
| Floating Mode Option For Powerful Dozing | | ✓ | ✓ | ✓ | ✓ |
| Power Shift Transmission | | X | X | X | ✓ |
| Automatic Transmission | | X | X | X | ✓ |
| Smart & Hi-tech Hydraulics | | ✓ | ✓ | ✓ | ✓ |
| Hi-speed Swing Mechanism | | ✓ | ✓ | ✓ | ✓ |
| Heavy Duty Structure, Boom Etc | | ✓ | ✓ | ✓ | ✓ |
| Heavy Duty Pin & Bushes(double Life) | | ✓ | ✓ | ✓ | ✓ |
| Low Fuel/ Engine Overheat Alarm Warning | | ✓ | ✓ | ✓ | ✓ |
| Tinted Glasses | | ✓ | ✓ | ✓ | ✓ |
| Kick Down (power Loading) | | X | X | X | ✓ |
| Backhoe Quick Hitch (option) | | O | O | O | O |
| Loader Quick Hitch (option) | | O | O | O | O |
| BULL Infomatics (option) | | O | O | O | O |

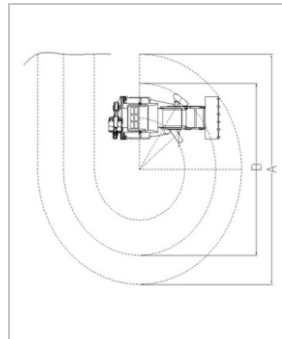
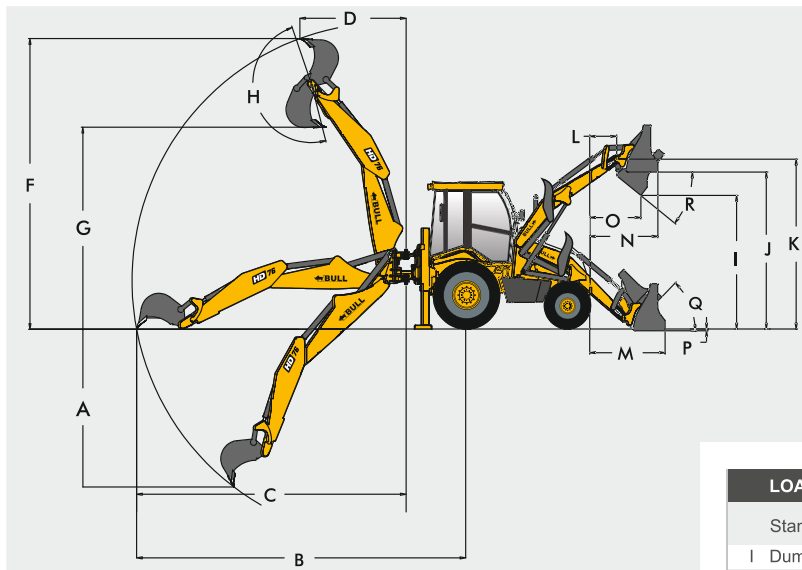

| TURNING CIRCLE | HD 76 | SD 76 | CH 76 |
|--------------------------------|--------|--------|--------|
| Inner wheels braked | | | |
| A Loader bucket outside | 9.18 | 9.18 | 9.18 |
| B Wheel outside | 6.37 | 6.37 | 6.37 |
| Inner wheels not braked | | | |
| A Loader bucket outside | 11.56 | 11.56 | 11.56 |
| B Wheel outside | 8.76 | 8.76 | 8.76 |
| DIESEL TANK CAPACITY | | | |
| Fuel Tank | 115Ltr | 115Ltr | 115Ltr |

| EXCAVATOR PERFORMANCE | HD 76 | SD 76 | CH 76 |
|---|-----------|-----------|-----------|
| Standard GP Bucket Capacity | 0.27 cu.m | 0.26 cu.m | 0.26 cu.m |
| A Maximum DIG depth | 4.60 m | 4.77 m | 4.77 m |
| B Reach Ground Level to Rear wheel center | 6.81 m | 6.77 m | 6.77 m |
| C Reach at Ground level to slew center | 5.50 m | 5.47 m | 5.47 m |
| D Reach at full height to slew center | 2.85 m | 2.82 m | 2.82 m |
| F Maximum working height | 6.08 m | 5.98 m | 5.98 m |
| G Maximum Load over Height | 4.38 m | 4.19 m | 4.19 m |
| H Bucket Rotation angle | 188 ° | 201 ° | 201 ° |
| Bucket Tear out force | 6531 kgf | 5936 kgf | 5936 kgf |
| Dipper Tear out force | 3150 kgf | 3109 kgf | 3109 kgf |

More Bucket Breakout Force & Backhoe Bucket Capacity

Variable piston pump
* Available for Super Smart & Challenger

Most fuel efficient backhoe in the world in its class*

CH 76 - SD 76 Square Cut 90° Foundation Bucket

Powder Coating : Scratch Resistant Painting

Effy Power system : for better power management and fuel saving

Engine high temperature Warning Alarm

SBS tech Side-By- Side Radiator

| LOADER PERFORMANCE | HD 76 | SD 76 | CH 76 |
|------------------------------------|-----------|-----------|-----------|
| Standard GP Bucket Capacity | 1.26 cu.m | 1.26 cu.m | 1.26 cu.m |
| I Dump Height | 2.96 m | 2.96 m | 2.96 m |
| J Load Over Height | 3.39 m | 3.39 m | 3.39 m |
| K Pin Height | 3.61 m | 3.61 m | 3.61 m |
| L Pin Forward Reach | 0.42 m | 0.42 m | 0.42 m |
| M Reach at Ground | 1.47 m | 1.47 m | 1.47 m |
| N Reach at full height | 1.28 m | 1.28 m | 1.28 m |
| O Reach at full Height BKT Dumping | 0.89 m | 0.89 m | 0.89m |
| P Below ground level DIG Depth | 0.1 m | 0.1m | 0.1m |
| Q Roll back at Ground | 49 ° | 49° | 49 ° |
| R Dump Angle | 45 ° | 45° | 45 ° |
| Bucket Break-out Force | 8183 kgf | 8183 kgf | 8183 kgf |
| Loader Arm Break-out Force | 5315 kgf | 5315 kgf | 5315 kgf |
| Pay Load | 2400 kgf | 2400 kgf | 2200 kgf |

*All specifications are subjected to change by BULL without prior notice.

WORLD CLASS COMFORT



Adjustable Steering

Customizable steering for effortless operation of the backhoe loader.

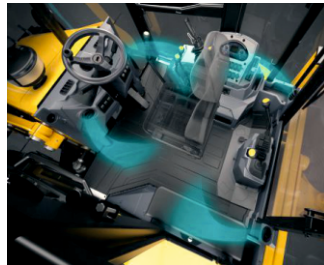

Air Conditioner

Heavy Duty RedDOT (USA) make with multi directional air flow climatic control.(optional)



ROPS & FOPS

Roll over & Fall over protection BULL cabin protects the operator from rollover or falling object.

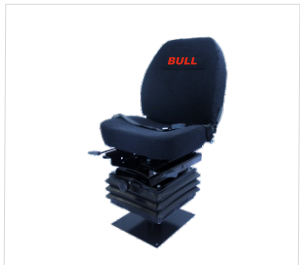

Suspension Seat

For enhanced cushion and comfort, reducing fatigue for prolonged operation.



Music system

Keeping you entertained through the longest workdays



Agile joystick drive machine

Smooth control, effortless operation, Precision at your fingertips.



42+ Types of Interchangeable BUCKET ATTACHMENTS

MORE ADAPTABLE | SEGMENT | EARNING



WHEN PERFORMANCE MEETS FLEXIBILITY

THE ALL ROUNDER MACHINE



SMART KID



SKID STEER
AV 490

NOW IN **64+**
COUNTRIES



HD100



HD96



HD76
CRUSHER KING



HD76



SD76
SUPER SMART



CH76
CHALLENGER



SD76
CHAMPION



SD76
LOADER

 **RAPID
SERVICE & SPARES
88832 88832**

LIVE **INFOMATIC**

78+
Dealers
across India
& Growing

PRIDE OF
INDIA 



BULL MACHINES PVT.LTD,
SF.NO. 5/1A, L&T By Pass junction,
Trichy Road, Coimbatore - 641 103.
INDIA.

Sales

☎ : +91 98422 87770
✉ : sales@bullmachine.com

Service and Spares

☎ : 88832 88832
✉ : care@bullmachine.com

International sales

✉ : exports@bullmachine.com

Dealer: