

The UNBEATABLE
Fuel saver & Performer

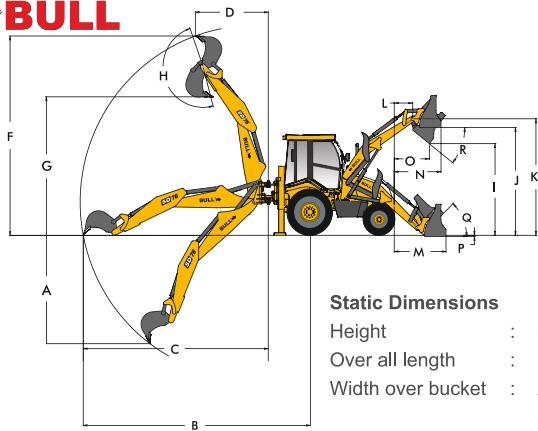

CHALLENGER
CH 76



Static Dimensions
 Height : 3.49m
 Over all length : 7.46m
 Width over bucket : 2.35m

LOADER PERFORMANCE		Challenger With Link Bracket	Challenger Without Link Bracket
Standard GP Bucket Capacity		1.26 cu.m	1.26 cu.m
I	Dump Height	2.96 m	2.96 m
J	Load Over Height	3.39 m	3.39 m
K	Pin Height	3.61 m	3.61 m
L	Pin Forward Reach	0.42 m	0.42 m
M	Reach at Ground	1.60 m	1.47 m
N	Reach at full height	1.42 m	1.28 m
O	Reach at full Height bkt Dumping	1.1m	0.89m
P	Below ground level DIG Depth	0.08m	0.1m
Q	Roll back at Ground	50 °	49 °
R	Dump Angle	45 °	45 °

Bucket Break-out Force	8183 kgf
Loader Arm Break-out Force	5315 kgf
Pay Load	2200 kgf
Lifting Capacity At Loader Arm Hook Pin	2600 kgf

EXCAVATOR PERFORMANCE		Challenger STANDARD	
Standard GP Bucket Capacity		0.26 cu.m	
A	Maximum DIG depth	4.77 m	15 ft-7.7in
B	Reach Ground Level to Rear wheel center	6.77 m	22 ft-2.53in
C	Reach at Ground level to slew center	5.47 m	17 ft-11.35in
D	Reach at full height to slew center	2.82 m	9 ft-3in
F	Maximum working height	5.98 m	19 ft-7.4in
G	Maximum Load over Height	4.19 m	13 ft-9.3in
H	Bucket Rotation angle	201°	
Bucket Tear out force		5936 kgf	
Dipper Tear out force		3109 kgf	

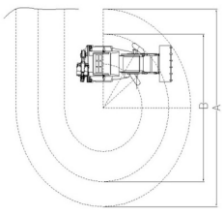

TURNING CIRCLE		CH 76
Inner wheels braked		
A	Loader bucket outside	9.18
B	Wheel outside	6.37
Inner wheels not braked		
A	Loader bucket outside	11.56
B	Wheel outside	8.76
DIESEL TANK CAPACITY		CH 76
Fuel Tank		115Ltr

ENGINE

Kirloskar 4R1040NA, BS-III (CEV) Diesel Engine (4160 CC)

Gross Power
49HP (36kW) @ 2000 rpm

Gross Torque
250Nm @ 1200 rpm

TYRES

FRONT 2WD- 9.00X16 - 16PR

REAR Industrial : 16.9X28 - 12PR
 Heavy Duty : 14X25 - 20PR

HYDRAULICS

Pump type : Load Sensing
 Variable Piston Pump
 Pressure : 3335 p.s.i (230 bar)
 Pump Flow : 119 lpm @ 2200 rpm
 128 lpm @ high rpm

WEIGHT

7550 Kgs

BACKHOE BUCKET OPTIONS

Excavator Standard bucket : 0.26 cu.m

TRANSMISSION

CARRARO
 Synchro-shuttle Transmission with integral torque convertor (Ratio : 2.64)

STEERING

Power Steering

ELECTRICAL

12V Battery Systems (150Ah)

SPEED

Forward Max : **36 Km/Hr**
 Reverse Max : **8.3 Km/Hr** (2nd Gear)



TILTABLE STEERING

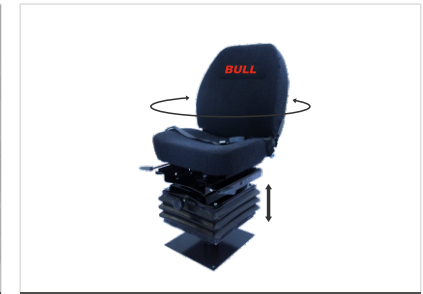

SUSPENSION SEAT (OPTIONAL)



ROPS FOPS ON FULL CABIN



OIL IMMERSED 3 DISC RAPID FILL BRAKE SYSTEM



TALLEST DUMPING BACKHOE LOADR

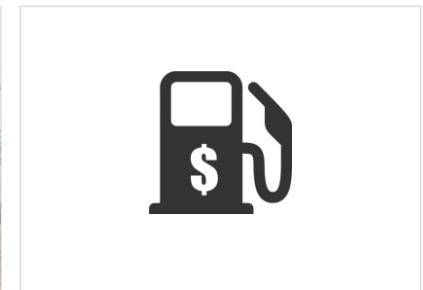

MOST FUEL EFFICIENT BACKHOE



POWDER COATED MACHINE

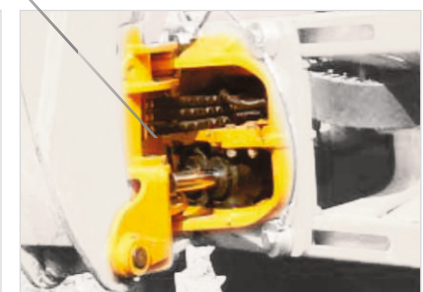

STEEL - SLIDING / SWIVEL KING POST



WHEN PERFORMANCE MEETS
FLEXIBILITY
THE ALL ROUNDER MACHINE



Quick coupler for interchange between backhoe bucket, Trench digger and Factory Fitted Rock breaker.



BQRSL Quick Hitch mechanism for Interchange 42+ types of Bucket options to the customer application.



ENGINE
Kirloskar 4R1040NA, Inline
FIP Engine



HYDRAULIC PUMP

AS MODE
(Auto Sensing -
Road / **L**oader / **E**co / **P**ower mode)
Backhoe

Automatically vehicle senses the different mode requirement (**R/L/E/P**) based on the demand of workload

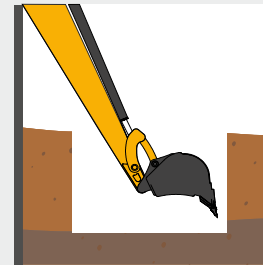

NEW SQUARE CUT BUCKET LINKAGE

Specially designed Bull Bucket linkage ensures 90 degree excavation for Civil foundation applications.



SMART SENSING VALVES

State of the Art loading sensing high efficiency valves.

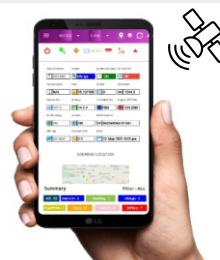

BULLINFORMATIC

Detailed Information Monitored Through Bull Informatics app



SMART KID



SKID STEER
AV 490

NOW IN **64+**
COUNTRIES



HD 100



HD 96



HD 76
CRUSHER KING



HD 76



SD 76
SUPER SMART



CH 76
CHALLENGER



SD 76
CHAMPION



SD 76
LOADER

 **RAPID
SERVICE & SPARES
88832 88832**

LIVE **INFOMATIC**

78+
Dealers
across India
& Growing

**PRIDE OF
INDIA** 



BULL MACHINES PVT.LTD,
SF.NO. 5/1A, L&T By Pass junction,
Trichy Road, Coimbatore - 641 103.
INDIA.

Sales

☎ : +91 98422 87770

✉ : sales@bullmachine.com

Service and Spares

☎ : 88832 88832

✉ : care@bullmachine.com

International sales

✉ : exports@bullmachine.com

Dealer:

